

Case 371 : Narrative

Case Vehicle (A): 2002 Ford	Vehicle (B): 1988 Chevrolet
Type: Explorer Sport, 4 x 4, 2-door SUV	Type: C1500, 2-door, 4 x 2 pickup
Driver: 26-year-old male	Driver: 67-year-old male
CDC: 11-FYEW-2	CDC: 99-0000-0

SITUATION

1 It was daylight and snowing, and the two-lane east-west asphalt roadway was wet but in good condition. 2 Case vehicle (A) was traveling west at an unknown speed in the westbound lane and 3 vehicle (B) was traveling east at an unknown speed in the eastbound lane. 4 The driver of vehicle (B) attempted to make a left turn into a private drive in front of case vehicle (A). The driver of case vehicle (A) did not have time to take any evasive action and the left front of case vehicle (A) struck the right front of vehicle (B). After the initial impact, 5 case vehicle (A) veered to the right, exited the road surface, and 6 went into a ditch. Both vehicles were towed due to damage.

The police accident report indicates C-level injuries for the driver of case vehicle (A) and B-level injuries for the driver of vehicle (B). Both drivers were transported by ambulance to a local hospital where they were treated and released.

GENERAL VEHICLE DAMAGE AND ESTIMATED CRASH SEVERITIES

7 Damage to case vehicle (A) was moderate. 8 Direct damage began at the left-front bumper corner and extended 92-cm to the right, resulting in 60-percent vehicle overlap (VOL). 9 The maximum crush was 34 cm and occurred at the left-front bumper corner. Vehicle (B) was unavailable for inspection.

Using the ROLDMISS crash-reconstruction program and a [10](#) [11](#) [12](#) [13](#) crush profile measured for case vehicle (A), the following impact severities were estimated for the head-on impact between the two vehicles:

Vehicle	Variable	Calculated Velocity Change - kph (mph)		
		Total	Longitudinal	Latitudinal
Case Vehicle (A)	delta V	29 (18)	-27 (-17)	10 (6)
Vehicle (B)	delta V	31 (19)	-29 (-18)	-11 (-7)

DESCRIPTION OF DAMAGE TO CASE VEHICLE (A)

Exterior

[14](#) In the front, the bumper, the hood and the left fender were crushed to the rear and to the right. The left bumper corner was shifted 36-cm to the right and [15](#) the right bumper corner was shifted 23-cm to the right. [16](#) There was a 5-cm gap between the Styrofoam bumper energy-absorbing device and the metal bumper support. The hood latch was damaged and jammed closed and [17](#) the left hood hinge was bent to the right, [18](#) but it is unknown if the right hood hinge was damaged. [19](#) The right-rear edge of the hood was buckled to the right and elevated, but it did not contact the windshield. [20](#) The upper-left corner of the windshield was chipped and [21](#) a crack extended from the corner to the center of the windshield.

[22](#) On the left side, the fender was crushed, [23](#) the left-front tire was flat, and [24](#) the inner portion of the wheel rim was bent and cracked. [25](#) The driver door was closed and operational and the left-side glazing was intact (the left-front window was about half open at the time of the crash). There was no measurable change in the left wheelbase.

[10](#) There was no damage to the roof or [26](#) to the rear of the vehicle.

[27](#) [28](#) The right fender was deflected to the right and the right wheelbase was reduced 4 cm. The right-side door remained closed and operational and there was no damage to the right-side glazing.

Interior

This vehicle was equipped with steering-wheel and dash-mounted frontal-impact airbags, and both [29](#) [30](#) [31](#) [32](#) deployed during the frontal impact. [33](#) The upper portion of the steering-wheel hub and upper airbag cover were scuffed, but [34](#) [35](#) [36](#) [37](#) there was no other damage to the steering-wheel airbag or module covers. [38](#) [39](#) [40](#) There was no damage to the steering-wheel rim or spokes. [41](#) The interior panel of the driver door, the door hardware, and the door armrest were scuffed. [42](#) The knee bolster cover was scuffed. [43](#) There was no other damage in the driver area.

[44](#) [45](#) In the right-front passenger area, there was no damage to the dash-mounted airbag or module covers. [47](#) There was no other damage in this part of the interior. [46](#) [47](#) [48](#) [49](#) [50](#) [51](#) [52](#) [53](#) [54](#) There were no intrusions and there was no other interior damage.

OCCUPANT KINEMATICS AND INJURIES

[55](#) The 5-ft, 10-in, 190-lb, 26-year-old, male driver was reportedly using the three-point belt and [56](#) the steering-wheel airbag deployed. There were no witness marks on the [57](#) D-ring or [58](#) sliding loop, but contusions to the driver's shoulder and abdomen are evidence of seatbelt usage.

On impact, the driver moved forward and to the left relative to the vehicle interior. He sustained a laceration to the bridge of the nose, probably due to contact by the deploying airbag. He sustained contusions to the left shoulder and across the abdomen, probably due to loading by the shoulder and lap belts.

The following table and attached drawing [59](#) summarize the injuries for the driver of case vehicle (A).

Occupant: Driver	Age: 26 years	Gender: Male		
Restraints: Three-point belt, steering-wheel airbag	Stature: 178 cm (5 ft, 10 in)	Mass: 86 kg (190 lb)		
Injury Description	A.I.S.	Injury Source		
		Definite	Probable	Possible
—	—	—	—	—
Laceration, bridge of nose	1	—	Airbag	—
Contusion, left shoulder	1	—	Shoulder belt	—
Contusion, across abdomen	1	—	Lap belt	—
Maximum A.I.S. Level	1	—	—	—
Injury Severity Score	1	—	—	—

CASE NO.: 371-03

CASE VEHICLE: 2002 Ford

TYPE: Explorer Sport, 4 x 4, 2-door SUV

OCCUPANT: Driver: 26-year-old male

STATURE: 178 cm (5 ft, 10 in) MASS: 86 kg (190 lb)

RESTRAINTS: 3-point belt, steering-wheel airbag

SEVERITY: MAIS - 1 : ISS - 1

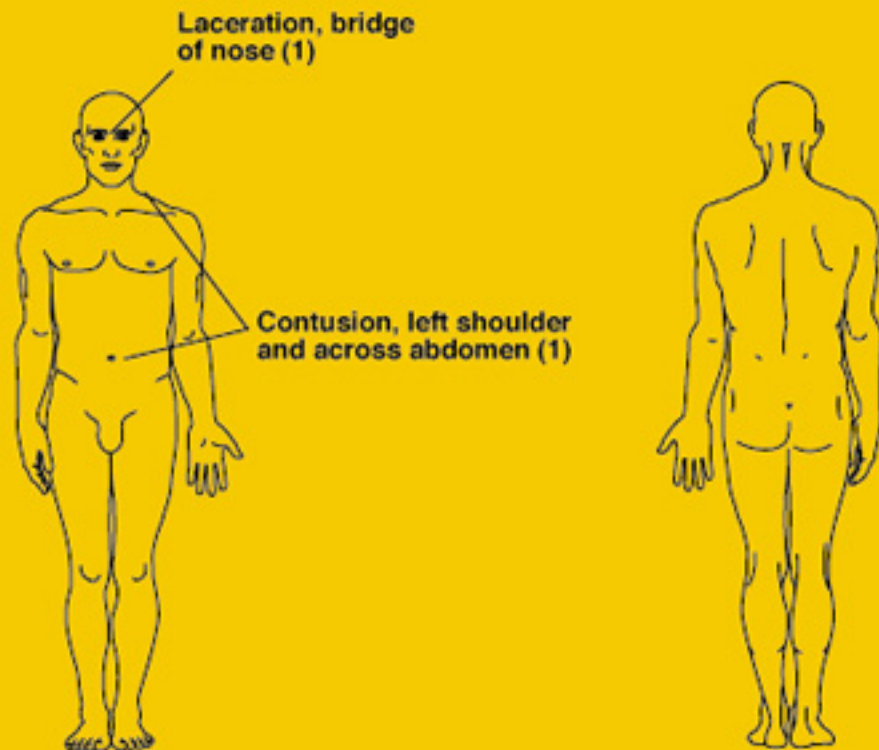

Case No.: 371-03

Case Veh. (A): 2002 Ford

Type: Explorer Sport, 4 x 4, 2-door SUV

Driver: 26-year-old male

Veh. (B): 1988 Chevrolet C1500, 4 x 2, 2-door pickup

Light Conditions: Daylight

Weather: Snow

Road Surface: Wet

Road Construction: Asphalt

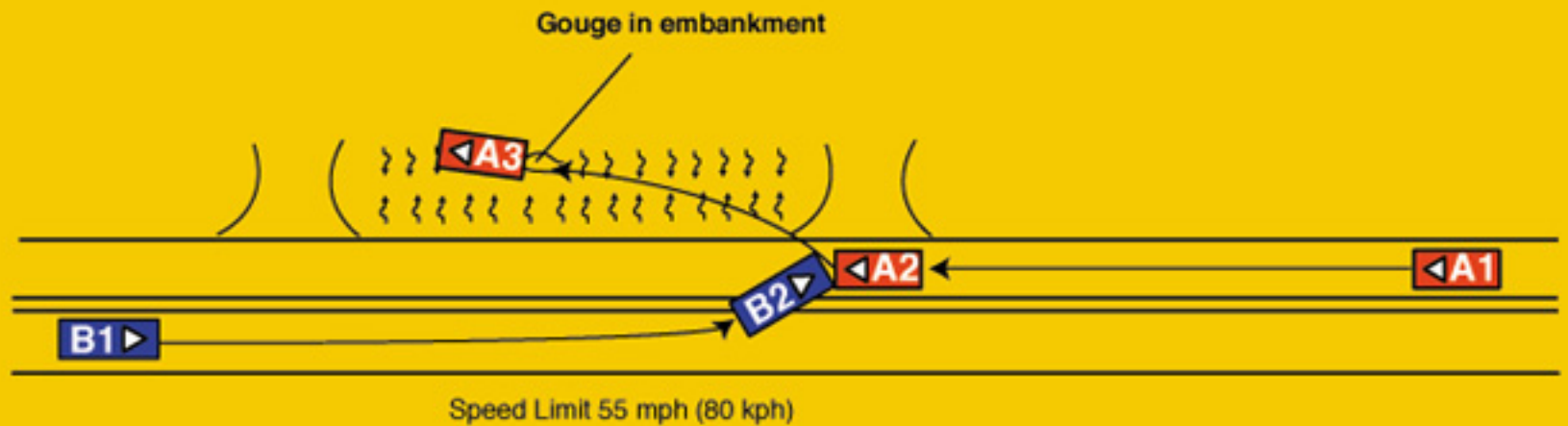

Vehicle Report

General

Conditions

Variable Number and Name	Code Value	Code Description	Other Options
V206 — Urban/Rural Area	2	Rural	more
V207 — Limited Access Highway	0	No	more
V208 — Road Total Lanes	2	2 lanes	more
V209 — Intersecting Road Total Lanes	6	Parking lot/driveway	more
V210 — Road Surface Type	1	Asphalt	more
V211 — Road Defects	0	No	more
V212 — Construction Zone	0	No	more
V213 — Road Alignment Vertical Plane	1	Level	more
V214 — Road Alignment Horizontal Plane	1	Straight	more
V215 — Surface Covering	22	Water - wet	more
V216 — Visibility Limitation	0	None	more
V217 — Visibility Obstruction	0	None	more
V218 — Speed Limit	6	86-90 km/h .. 55 mph	more
V219 — Precipitation Type	2	Snow	more
V220 — Precipitation Rate	9	Unknown	more
V221 — Temperature	9	Unknown	more
V222 — Crosswind	9	Unknown	more
V223 — Light Conditions	1	Daylight	more
V224 — Mechanical Malfunction Mention	0	No	more
V225 — Case Vehicle and Object	0	No	more

V226 — Case Vehicle Rollover	0	No	more
V227 — Case Vehicle Ran Off Roadway	0	No	more
V228 — Moving Case Vehicle/Contacted Moving Vehicle	1	Yes	more
V229 — Case Vehicle/Contacted Stopped Vehicle	0	No	more
V230 — Stopped Case Vehicle/Contactd Vehicle	0	No	more
V231 — Total Vehicles Hit By Case Vehicle	1	1 vehicle	more
V232 — Any Fire in Crash	0	No	more
V233 — Max Police Severity-PAR	2	B - Non-Incapacitating Injury	more
V234 — Driver Alcohol Involvement	0	Had not been drinking	more
V235 — Driver Alcohol BAC	80	Not tested	more
V236 — Driver Impairment Mention	0	No	more
V237 — Driven/Towed From Scene	2	Towed Due to Damage	more

Other Vehicle

Variable Number and Name	Code Value	Code Description	Other Options
V301 — Other Vehicle VIN	2GCDC1427J11	—	—
V302 — Other Vehicle Manufacturer/Body Code	21312	—	—
V303 — Other Vehicle Manufacturer	213	Chevrolet	more
V304 — Other Vehicle Body Code	12	Pickup truck (no canopy or shell)	more
V305 — Other Vehicle Make/Model	2902	Fleetside, Stepside, 1500, C/10	more
V306 — Other Vehicle Model Year	1988	—	—
V307 — Other Vehicle Mass	001658 kg	—	—
V308 — Other Vehicle Number	0	No separate report	more
V309 — Other Vehicle Number of Occupants	01	—	—
V310 — Other Vehicle Traveling Speed	999	Unknown	more
V311 — Highest Police Injury Severity	2	B - Non-Incapacitating Injury	more
V312 — Other Vehicle Type	12	Pickup truck	more
V313 — Other Vehicle Wheelbase (cm)	298 cm	—	—
V314 — Average Track Width	999	Unknown	more
V315 — Overall Length	493 cm	—	—
V316 — Overall Width (OAW)	194 cm	—	—
V317 — Front Overhang (FOH)	089 cm	—	—
V318 — Rear Overhang (ROH)	105 cm	—	—
V319 — Undeformed End Width (UEW)	180 cm	—	—
V320 — Engine Displacement	4.3 l	—	—
V321 — Engine: Number of	06	—	—

Cylinders			
V322 — Direct Damage Length (DDL)	999	Unknown	more
V323 — Front-End Overlap % (FEO)	99	Missing or Not applicable	more
V324 — Vehicle Overlap % (VOL)	99	Missing or Not applicable	more

Case Vehicle

General

Variable Number and Name	Code Value	Code Description	Other Options
V401 — VIN	1FMYU70E42UB	—	—
V402 — Manufacturer/Body Code	12114	—	—
V403 — Vehicle Manufacturer	121	Ford	more
V404 — Vehicle Body Code	14	—	—
V405 — Make/Model Code	3131	Explorer MPV	more
V406 — Model Year	2002	—	—
V407 — Vehicle Mass	001798 kg	—	—
V408 — Odometer Reading	022158 miles	—	—
V409 — Number of Occupants	01	—	—
V410 — Traveling Speed	999	Unknown	more
V411 — Body Type	21	Small utility (e.g. Jeep, Scout, Bronco)	more
V412 — Stolen Vehicle	8	Not currently collected	more
V413 — Body Structure	1	Body and frame	more
V414 — Transmission Type	1	Automatic	more
V415 — Transmission Lever Location	3	Column	more
V416 — Steering	1	Power	more
V417 — Brakes	1	Power	more
V418 — Brake Type	3	Disc - all wheels	more
V419 — Brake Anti-lock Device	2	Four-wheel	more
V420 — Air Conditioning in Vehicle	8	Not currently collected	more
V421 — Drive Type	3	Four wheel	more

V422 — Dual Rear Wheels	0	No	more
V423 — Original Restraint System Type	3	Airbag	more
V424 — Equipped With Roll Bar	0	No	more
V425 — Roof Type	4	Sun roof closed	more
V426 — Wheelbase	259 cm	—	—
V427 — Anti-lacerative Glass	0	None	more
V428 — Average Track Width	149 cm	—	—
V429 — Overall Length	458 cm	—	—
V430 — Overall Width (OAW)	178 cm	—	—
V431 — Front Overhang	088 cm	—	—
V432 — Rear Overhang	112 cm	—	—
V433 — Undeformed End Width (UEW)	150 cm	—	—
V434 — Engine Displacement	4.0 <i>l</i>	—	—
V435 — Engine: Number of Cylinders	06	—	—
V436 — Direct Damage Length (DDL)	092 cm	—	—
V437 — Front End Overlap % (FEO)	61	—	—
V438 — Vehicle Overlap % (VOL)	60	—	—

Case Vehicle

Damage

Description

Variable Number and Name	Code Value	Code Description	Other Options
V501 — Maximum Crush - Front	034 cm	—	—
V502 — Maximum Crush - Right Side	000 cm	No crush (or less than 1 cm.)	more
V503 — Maximum Crush - Rear	000 cm	No crush (or less than 1 cm.)	more
V504 — Maximum Crush - Left Side	000 cm	No crush (or less than 1 cm.)	more
V505 — Maximum Crush - Roof	000 cm	No crush (or less than 1 cm.)	more
V506 — Maximum Crush - Other	000 cm	No crush (or less than 1 cm.)	more
V507 — Are Events In Chronological Order	1	Yes	more
V508 — Event 1 Impact Location	1	On Roadway	more
V509 — Event 1 Impact Configuration	11	FRONT of case veh - FRONT of contacted Vehicle	more
V510 — Event 1 Object/Vehicle Contacted	12	Pickup truck	more
V511 — Event 2 Impact Location	8	No 2nd event	more
V512 — Event 2 Impact Configuration	88	No 2nd event	more
V513 — Event 2 Object/Vehicle Contacted	00	No object/vehicle contacted	more
V514 — Event 3 Impact Location	8	No 3rd event	more
V515 — Event 3 Impact Configuration	88	No 3rd event	more
V516 — Event 3 Object/Vehicle Contacted	00	No object/vehicle contacted	more
V517 — Event 4 Impact Location	8	No 4th event	more
V518 — Event 4 Impact Configuration	88	No 4th event	more

V519 — Event 4 Object/Vehicle Contacted	00	No object/vehicle contacted	more
V520 — Event 5 Impact Location	8	No 5th event	more
V521 — Event 5 Impact Configuration	88	No 5th event	more
V522 — Event 5 Object/Vehicle Contacted	00	No object/vehicle contacted	more
V523 — Event 6 Impact Location	8	No 6th event	more
V524 — Event 6 Impact Configuration	88	No 6th event	more
V525 — Event 6 Object/Vehicle Contacted	00	No object/vehicle contacted	more
V526 — Event 7 Impact On Road	8	No 7th event	more
V527 — Event 7 Impact Configuration	88	No 7th event	more
V528 — Event 7 Object/Vehicle Contacted	00	No object/vehicle contacted	more
V529 — Primary CDC Case Vehicle -event Number	1	Event 1	more
V530 — Primary CDC Case Vehicle - impact speed	999	Unknown	more
V531 — Primary CDC Case Vehicle - Estimated By	1	Investigator	more
V532 — Primary CDC Case Vehicle -crush	034	—	—
V533 — Primary CDC Case Vehicle -clock #1	11	11 o'clock	more
V534 — Primary CDC Case Vehicle letter 1 #1	06	F - Front	more
V535 — Primary CDC Case Vehicle letter 2 #1	25	Y - Side or end (F + P or L + C)	more
V536 — Primary CDC Case Vehicle letter 3 #1	05	E - Everything below belt line	more
V537 — Primary CDC Case Vehicle letter 4 #1	23	W - Wide impact area	more
V538 — Primary CDC Case Vehicle Extent #1	02	Extent 2	more
V539 — Primary CDC Case Vehicle -CDC #1	11FYEW2	—	—

V541 — Primary CDC Case Vehicle letter 1 #2	00	Missing Data/Not applicable	more
V542 — Primary CDC Case Vehicle letter 2 #2	00	Missing Data/Not applicable	more
V543 — Primary CDC Case Vehicle letter 3 #2	00	Missing Data/Not applicable	more
V544 — Primary CDC Case Vehicle letter 4 #2	00	Missing Data/Not applicable	more
V545 — Primary CDC Case Vehicle Extent #2	00	Missing Data/Not applicable	more
V546 — Primary CDC Case Vehicle -CDC #2	9800000	—	—
V547 — Primary CDC Contacted Vehicle - Impact Speed	999	Unknown	more
V548 — Primary CDC Contacted Vehicle - Estimated By	1	Investigator	more
V549 — Primary CDC Contacted Vehicle -crush	999	Unknown	more
V550 — Primary CDC Contacted Vehicle -clock #1	99	Unknown or no damage	more
V551 — Primary CDC Contacted Vehicle letter 1 #1	00	Missing Data/Not applicable	more
V552 — Primary CDC Contacted Vehicle letter 2 #1	00	Missing Data/Not applicable	more
V553 — Primary CDC Contacted Vehicle letter 3 #1	00	Missing Data/Not applicable	more
V554 — Primary CDC Contacted Vehicle letter 4 #1	00	Missing Data/Not applicable	more
V555 — Primary CDC Contacted Vehicle Extent #1	00	Missing Data/Not applicable	more
V556 — Primary CDC Contacted Vehicle -CDC #1	9900000	—	—
V558 — Primary CDC Contacted Vehicle letter 1 #2	00	Missing Data/Not applicable	more
V559 — Primary CDC Contacted Vehicle letter 2 #2	00	Missing Data/Not applicable	more
V560 — Primary CDC Contacted Vehicle letter 3 #2	00	Missing Data/Not applicable	more
V561 — Primary CDC Contacted Vehicle letter 4 #2	00	Missing Data/Not applicable	more

V562 — Primary CDC Contacted Vehicle Extent #2	00	Missing Data/Not applicable	more
V563 — Primary CDC Contacted Vehicle -CDC #2	9900000	—	—
V564 — Secondary CDC Case Vehicle - Event No	8	Not applicable	more
V565 — Secondary CDC Case Vehicle - Impact Speed	998	Not Applicable	more
V566 — Secondary CDC Case Vehicle - Estimated By	8	Not applicable (no vehicle/no impact)	more
V567 — Secondary CDC Case Vehicle -crush	998	Not Applicable	more
V568 — Secondary CDC Case Vehicle -clock #1	98	Not Applicable	more
V569 — Secondary CDC Case Vehicle letter 1 #1	00	Missing Data/Not applicable	more
V570 — Secondary CDC Case Vehicle letter 2 #1	00	Missing Data/Not applicable	more
V571 — Secondary CDC Case Vehicle letter 3 #1	00	Missing Data/Not applicable	more
V572 — Secondary CDC Case Vehicle letter 4 #1	00	Missing Data/Not applicable	more
V573 — Secondary CDC Case Vehicle Extent #1	00	Missing Data/Not applicable	more
V574 — Secondary CDC Case Vehicle -CDC #1	9800000	—	—
V576 — Secondary CDC Case Vehicle letter 1 #2	00	Missing Data/Not applicable	more
V577 — Secondary CDC Case Vehicle letter 2 #2	00	Missing Data/Not applicable	more
V578 — Secondary CDC Case Vehicle letter 3 #2	00	Missing Data/Not applicable	more
V579 — Secondary CDC Case Vehicle letter 4 #2	00	Missing Data/Not applicable	more
V580 — Secondary CDC Case Vehicle Extent #2	00	Missing Data/Not applicable	more
V581 — Secondary CDC Case Vehicle -CDC #2	9800000	—	—
V582 — Secondary CDC Contacted Vehicle - Impact Speed	998	Not Applicable	more

V583 — Secondary CDC Contacted Vehicle - Estimated By	8	Not applicable (no vehicle/no impact)	more
V584 — Secondary CDC Contacted Vehicle -crush	998	Not Applicable	more
V585 — Secondary CDC Contacted Vehicle -clock #1	98	Not Applicable	more
V586 — Secondary CDC Contacted Vehicle letter 1 #1	00	Missing Data/Not applicable	more
V587 — Secondary CDC Contacted Vehicle letter 2 #1	00	Missing Data/Not applicable	more
V588 — Secondary CDC Contacted Vehicle letter 3 #1	00	Missing Data/Not applicable	more
V589 — Secondary CDC Contacted Vehicle letter 4 #1	00	Missing Data/Not applicable	more
V590 — Secondary CDC Contacted Vehicle Extent #1	00	Missing Data/Not applicable	more
V591 — Secondary CDC Contacted Vehicle -CDC #1	9800000	—	—
V593 — Secondary CDC Contacted Vehicle letter 1 #2	00	Missing Data/Not applicable	more
V594 — Secondary CDC Contacted Vehicle letter 2 #2	00	Missing Data/Not applicable	more
V595 — Secondary CDC Contacted Vehicle letter 3 #2	00	Missing Data/Not applicable	more
V596 — Secondary CDC Contacted Vehicle letter 4 #2	00	Missing Data/Not applicable	more
V597 — Secondary CDC Contacted Vehicle Extent #2	00	Missing Data/Not applicable	more
V598 — Secondary CDC Contacted Vehicle -CDC #2	9800000	—	—

Crash Severity

Variable Number and Name	Code Value	Code Description	Other Options
V601 — Case Vehicle Primary Impact Number	1	—	—
V602 — Primary Impact Total Delta-V	029 kph	—	—
V603 — Primary Case Vehicle Reconstructed Longitudinal Delta-V	-027 kph	—	—
V604 — Primary Case Vehicle Reconstructed Lateral Delta-V	0010 kph	—	—
V605 — Primary Case Vehicle Reconstructed Crush Energy	0070 kJ	—	—
V606 — Primary Impact Case Vehicle - reconstruction	22	Reconstructed, moderate confidence level	more
V607 — Primary Case Vehicle Reconstruction Mode	2	CDC & detailed damage	more
V608 — Primary Contacted Vehicle Reconstructed Total Delta-V	031 kph	—	—
V609 — Primary Contacted Vehicle Reconstructed Longitudinal Delta-V	-029 kph	—	—
V610 — Primary Contacted Vehicle Reconstructed Lateral Delta-V	-011 kph	—	—
V611 — Primary Contacted Vehicle Reconstructed Crush Energy	0080 kJ	—	—
V612 — Case Vehicle Secondary Impact Number	8	—	—
V613 — Secondary Case Vehicle Reconstructed Total Delta-V	888	N/A	more
V614 — Secondary Case Vehicle Reconstructed Longitudinal Delta-V	8888	—	—
V615 — Secondary Case Vehicle Reconstructed Lateral Delta-V	8888	—	—
V616 — Secondary Case Vehicle Reconstructed Crush Energy	8888	—	—
V617 — Secondary Case Vehicle Reconstruction Note	88	—	—
V618 — Secondary Case Vehicle Reconstruction Mode	8	Not applicable	more

V619 — Secondary Contacted Vehicle Reconstructed Total Delta-V	888	N/A	more
V620 — Secondary Contacted Vehicle Reconstructed Longitudinal Delta-V	8888	—	—
V621 — Secondary Contacted Vehicle Reconstructed Lateral Delta-V	8888	—	—
V622 — Secondary Contacted Vehicle Reconstructed Crush Energy	8888	—	—
V623 — Case Vehicle Primary Impact Number	1	—	—
V624 — Primary Case Vehicle Reconstructed Total EBS	030 kph	—	—
V625 — Primary Case Vehicle Reconstructed Longitudinal EBS	-028 kph	—	—
V626 — Primary Case Vehicle Reconstructed Lateral EBS	0010 kph	—	—
V627 — Primary Case Vehicle Reconstructed Crush Energy	0070 kJ	—	—
V628 — Primary Case Vehicle Reconstruction Note	22	Reconstructed, moderate confidence level	more
V629 — Primary Case Vehicle Reconstruction Mode	2	CDC & detailed damage	more
V630 — Primary Contacted Vehicle Reconstruction Total EBS	999	Unknown	more
V631 — Primary Contacted Vehicle Reconstruction Longitudinal EBS	9999	—	—
V632 — Primary Contacted Vehicle Reconstruction Lateral EBS	9999	—	—
V633 — Primary Contacted Vehicle Reconstruction Crush Energy	9999	—	—
V634 — Case Vehicle Secondary Impact Number	8	Not applicable	more
V635 — Secondary Case Vehicle Reconstruction Total EBS	888	N/A	more
V636 — Secondary Case Vehicle Reconstruction Longitudinal EBS	8888	—	—
V637 — Secondary Case Vehicle Reconstruction Lateral EBS	8888	—	—
V638 — Secondary Case Vehicle Reconstruction Crush Energy	8888	—	—
V639 — Secondary Case Vehicle Reconstruction	88	—	—

Note			
V640 — Secondary Case Vehicle Reconstruction Mode	8	Not applicable	more
V641 — Secondary Contacted Vehicle Reconstruction Total EBS	888	N/A	more
V642 — Secondary Contacted Vehicle Reconstruction Longitudinal EBS	8888	—	—
V643 — Secondary Contacted Vehicle Reconstruction Lateral EBS	8888	—	—
V644 — Secondary Contacted Vehicle Reconstruction Crush Energy	8888	—	—
V645 — Case Vehicle Reconstructed Impact Number	1	—	—
V646 — Case Vehicle Impact 1 Plane	1	Bumper	more
V647 — Case Vehicle Impact 1 Direct Damage Length [DDL]	092 cm	—	—
V648 — Case Vehicle Impact 1 Max Crush	034 cm	—	—
V649 — Case Vehicle Impact 1 Field-L	149 cm	—	—
V650 — Case Vehicle Impact 1 C1	034 cm	—	—
V651 — Case Vehicle Impact 1 C2	024 cm	—	—
V652 — Case Vehicle Impact 1 C3	021 cm	—	—
V653 — Case Vehicle Impact 1 C4	019 cm	—	—
V654 — Case Vehicle Impact 1 C5	020 cm	—	—
V655 — Case Vehicle Impact 1 C6	027 cm	—	—
V656 — Case Vehicle Impact 1 +/- D	-029 cm	—	—
V657 — Case Vehicle Reconstructed Impact Number	9	Unknown	more
V658 — Case Vehicle Impact 2 Plane	9	Unknown	more
V659 — Case Vehicle Impact 2 Direct Damage Length [DDL]	999	Unknown	more
V660 — Case Vehicle Impact 2 Max Crush	999	Unknown	more
V661 — Case Vehicle Impact 2 Field-L	999	Unknown	more
V662 — Case Vehicle Impact 2 C1	999	Unknown	more
V663 — Case Vehicle Impact 2 C2	999	Unknown	more

V664 — Case Vehicle Impact 2 C3	999	Unknown	more
V665 — Case Vehicle Impact 2 C4	999	Unknown	more
V666 — Case Vehicle Impact 2 C5	999	Unknown	more
V667 — Case Vehicle Impact 2 C6	999	Unknown	more
V668 — Case Vehicle Impact 2 +/- D	9999	—	—
V669 — Other Vehicle Reconstructed Impact Number	9	Unknown	more
V670 — Other Vehicle Impact 1 Plane	9	Unknown	more
V671 — Other Vehicle Impact 1 Direct Damage Length [DDL]	999	Unknown	more
V672 — Other Vehicle Impact 1 Max Crush	999	Unknown	more
V673 — Other Vehicle Impact 1 Field-L	999	Unknown	more
V674 — Other Vehicle Impact 1 C1	999	Unknown	more
V675 — Other Vehicle Impact 1 C2	999	Unknown	more
V676 — Other Vehicle Impact 1 C3	999	Unknown	more
V677 — Other Vehicle Impact 1 C4	999	Unknown	more
V678 — Other Vehicle Impact 1 C5	999	Unknown	more
V679 — Other Vehicle Impact 1 C6	999	Unknown	more
V680 — Other Vehicle Impact 1 +/- D	9999	—	—
V681 — Other Vehicle Reconstructed Impact Number	9	Unknown	more
V682 — Other Vehicle Impact 2 Plane	9	Unknown	more
V683 — Other Vehicle Impact 2 Direct Damage Length [DDL]	999	Unknown	more
V684 — Other Vehicle Impact 2 Max Crush	999	Unknown	more
V685 — Other Vehicle Impact 2 Field-L	999	Unknown	more
V686 — Other Vehicle Impact 2 C1	999	Unknown	more
V687 — Other Vehicle Impact 2 C2	999	Unknown	more
V688 — Other Vehicle Impact 2 C3	999	Unknown	more
V689 — Other Vehicle Impact 2 C4	999	Unknown	more
V690 — Other Vehicle Impact 2 C5	999	Unknown	more

V691 — Other Vehicle Impact 2 C6	999	Unknown	more
V692 — Other Vehicle Impact 2 +/- D	9999	—	—

Case Vehicle

Tires & Rims

Variable Number and Name	Code Value	Code Description	Other Options
V701 — Left Front Wheel Damaged	1	Yes	more
V702 — Right Front Wheel Damaged	0	No	more
V703 — Right Rear Wheel Damaged	0	No	more
V704 — Left Rear Wheel Damaged	0	No	more
V705 — Left Front Tire Tread Type	4	All Weather	more
V706 — Right Front Tire Tread Type	4	All Weather	more
V707 — Right Rear Tire Tread Type	4	All Weather	more
V708 — Left Rear Tire Tread Type	4	All Weather	more
V709 — Left Front Carcass Construction	3	Radial	more
V710 — Right Front Carcass Construction	3	Radial	more
V711 — Right Rear Carcass Construction	3	Radial	more
V712 — Left Rear Carcass Construction	3	Radial	more
V717 — Left Front Tire Size	P25570R16	—	—
V718 — Right Front Tire Size	P25570R16	—	—
V719 — Right Rear Tire Size	P25570R16	—	—
V720 — Left Rear Tire Size	P25570R16	—	—

Case Vehicle

Fuel, Tank, Fire

Variable Number and Name	Code Value	Code Description	Other Options
V801 — Propulsive Fuel Type	1	Gasoline	more
V802 — Main Tank Location	222	Within frame/centered laterally - within vertically	more
V803 — Main Filler Cap Location	113	Left of frame laterally - above vertically	more
V804 — Main Tank Material	1	Steel	more
V805 — Aux Tank Type	8	Not applicable (not equipped)	more
V806 — Aux Tank Location	888	Not applicable (not equipped)	more
V807 — Aux Filler Cap Location	888	Not applicable (not equipped)	more
V808 — Aux Tank Material	8	Not applicable	more
V901 — Fuel Leakage From Crash	0	No	more
V1001 — Fire In Or On Case Vehicle	0	No	more

Case Vehicle

Exterior

Variable Number and Name	Code Value	Code Description	Other Options
V1101 — Hood Latch Released	0	No	more
V1102 — Hood Latch Damaged	1	Yes	more
V1103 — Hood Latch Jammed	1	Yes	more
V1104 — Left Hood Hinge Damaged	1	Yes	more

V1105 — Left Hood Hinge Separated	0	No	more
V1106 — Right Hood Hinge Damaged	9	Unknown	more
V1107 — Right Hood Hinge Separated	0	No	more
V1108 — Hood Remained On Vehicle	1	Yes	more
V1109 — Rear Hood Edge Elevated	1	Yes	more
V1110 — Edge Contacted Windshield	0	No	more
V1111 — Edge Penetrated Windshield	8	Not applicable	more
V1112 — Hood Latch Location	1	Front of Vehicle	more
V1113 — Eng/Transmissn Mount Separation	0	No	more
V1114 — Steerng Column Flex Coupling	9	Unknown if equipped	more
V1115 — Steerng Column Coupling Damaged	9	Unknown	more
V1116 — Steerng Column Coupling Separated	9	Unknown	more
V1117 — Eng Comp Telescopng Unit	88	Not collected	more
V1118 — Comp Orig/Telescopd Diff	888	Not collected	more
V1119 — Left Side Body Mount Separation	0	No	more
V1120 — Upper Left A-pillar Separation	0	No	more
V1121 — Lower Left A-pillar Separation	0	No	more
V1122 — Upper Left B-pillar Separation	0	No	more
V1123 — Lower Left B-pillar Separation	0	No	more
V1124 — Upper Left C-pillar Separation	0	No	more

V1125 — Lower Left C-pillar Separation	0	No	more
V1126 — Upper Left D-pillar Separation	8	Not applicable (not equipped)	more
V1127 — Lower Left D-pillar Separation	8	Not applicable (not equipped)	more
V1128 — Left Front Door Opening Cause	0	Door did not open	more
V1129 — Left Rear Door Opening Cause	8	Not applicable (no left rear door)	more
V1130 — Left Front Door Jammed Closed	0	No	more
V1131 — Left Rear Door Jammed Closed	8	Not applicable (no left rear door)	more
V1132 — Rear Door Type	2	One-way tailgate	more
V1133 — Rear Door Opening Cause	0	Door did not open	more
V1134 — Rear Door Jammed Closed	0	No	more
V1135 — Luggage Partition Damagd	8	Not applicable	more
V1136 — Spare Tire Status	8	Not collected	more
V1137 — Trailer Hitch Type	0	No hitch	more
V1138 — Trailer Type	0	No trailer	more
V1139 — Right Side Body Mount Separation	0	No	more
V1140 — Upper Right A-pillar Separation	0	No	more
V1141 — Lower Right A-pillar Separation	0	No	more
V1142 — Upper Right B-pillar Separation	0	No	more
V1143 — Lower Right B-pillar Separation	0	No	more
V1144 — Upper Right C-pillar Separation	0	No	more
V1145 — Lower Right C-pillar Separation	0	No	more

V1146 — Upper Right D-pillar Separation	8	Not applicable (not equipped)	more
V1147 — Lower Right D-pillar Separation	8	Not applicable (not equipped)	more
V1148 — Right Front Door Opening Cause	00	Door did not open	more
V1149 — Right Rear Door Opening Cause	98	Not applicable (no right rear door)	more
V1150 — Right Front Door Jammed Closed	0	No	more
V1151 — Right Rear Door Jammed Closed	8	Not applicable (no right rear door)	more
V1152 — Van Rear Door Type	8	Not applicable (not a van)	more
V1153 — Windshield Cracked		Yes	more
V1154 — Windshield Broken	0	No	more
V1155 — Windshield Cracked or Broken by Occupant	8	Not applicable	more
V1156 — Bond Separation Extent	0	None	more
V1157 — Windshield Code		—	—
V1158 — Did Sun/T Roof Open	0	No	more

Case Vehicle

Steering

Column/Rim

Variable Number and Name	Code Value	Code Description	Other Options
V1201 — Steering Wheel Rim Damage	0	None	more
V1202 — Number of Steering Wheel Spokes	4	4 spokes	more
V1203 — Steering Wheel Spoke Damage	0	None	more
V1204 — Column Tilt Feature	3	Middle	more
V1205 — Column Swing-away Feature	0	Not equipped	more
V1206 — Column Telescoping Feature	0	Not equipped	more
V1207 — Wheel Energy Absorb Device	8	Not collected	more
V1208 — Wheel Ea Orig/Damaged Diff	888	Not collected	more
V1209 — Column Energy Absorb Device	88	Not collected	more
V1210 — Column Ea Orig/Comprss Diff	888	Not collected	more
V1211 — Shear Capsule Separation	888	Not collected	more
V1212 — Column Vertical Rotation	0	No apparent rotation	more
V1213 — Column Lateral Rotation	0	No apparent rotation	more
V1214 — Steering Wheel Hub Damage	1	Occupant contact	more

Case Vehicle

Intrusion

Variable Number and Name	Code Value	Code Description	Other Options
V1301 — Occupant Compartment Intrusion	0	No	more
V1302 — Was Intrusion Catastrophic	8	Not applicable	more
V1303 — Intrusion Number 01	00	No Intrusion, None	more
V1304 — Intrusion 01 Occupant Space Number	00	No Intrusion, None	more
V1305 — Intrusion 01 Intruding Object	00	No Intrusion, None	more
V1306 — Intrusion 01 Assoc Event Number	0	No Intrusion, None	more
V1307 — Intrusion 01 Max Intrusion X-axis	00 cm	0 cm or No Intrusion	more
V1308 — Intrusion 01 Max Intrusion Y-axis	00 cm	0 cm or No Intrusion	more
V1309 — Intrusion 01 Max Intrusion Z-axis	00 cm	0 cm or No Intrusion	more
V1310 — Intrusion 01 Occupant Number	00	No contact or no intrusion	more
V1311 — Intrusion 01 Injury Number	00	No injury or no intrusion	more
V1312 — Intrusion 01 Occupant Number	00	No contact or no intrusion	more
V1313 — Intrusion 01 Injury Number	99	Contact, injury unknown or data not collected	more
V1314 — Intrusion Number 02	00	No Intrusion, None	more
V1315 — Intrusion 02 Occupant Space Number	00	No Intrusion, None	more
V1316 — Intrusion 02 Intruding Object	00	No Intrusion, None	more
V1317 — Intrusion 02 Assoc Event Number	0	No Intrusion, None	more
V1318 — Intrusion 02 Max Intrusion X-axis	00 cm	0 cm or No Intrusion	more

V1319 — Intrusion 02 Max Intrusion Y-axis	00 cm	0 cm or No Intrusion	more
V1320 — Intrusion 02 Max Intrusion Z-axis	00 cm	0 cm or No Intrusion	more
V1321 — Intrusion 02 Occupant Number	00	No contact or no intrusion	more
V1322 — Intrusion 02 Injury Number	00	No injury or no intrusion	more
V1323 — Intrusion 02 Occupant Number	00	No contact or no intrusion	more
V1324 — Intrusion 02 Injury Number	99	Contact, injury unknown or data not collected	more
V1325 — Intrusion Number 03	00	No Intrusion, None	more
V1326 — Intrusion 03 Occupant Space Number	00	No Intrusion, None	more
V1327 — Intrusion 03 Intruding Object	00	No Intrusion, None	more
V1328 — Intrusion 03 Assoc Event Number	0	No Intrusion, None	more
V1329 — Intrusion 03 Max Intrusion X-axis	00 cm	0 cm or No Intrusion	more
V1330 — Intrusion 03 Max Intrusion Y-axis	00 cm	0 cm or No Intrusion	more
V1331 — Intrusion 03 Max Intrusion Z-axis	00 cm	0 cm or No Intrusion	more
V1332 — Intrusion 03 Occupant Number	00	No contact or no intrusion	more
V1333 — Intrusion 03 Injury Number	00	No injury or no intrusion	more
V1334 — Intrusion 03 Occupant Number	00	No contact or no intrusion	more
V1335 — Intrusion 03 Injury Number	99	Contact, injury unknown or data not collected	more
V1336 — Intrusion Number 04	00	No Intrusion, None	more
V1337 — Intrusion 04 Occupant Space Number	00	No Intrusion, None	more
V1338 — Intrusion 04 Intruding Object	00	No Intrusion, None	more

V1339 — Intrusion 04 Assoc Event Number	0	No Intrusion, None	more
V1340 — Intrusion 04 Max Intrusion X-axis	00 cm	0 cm or No Intrusion	more
V1341 — Intrusion 04 Max Intrusion Y-axis	00 cm	0 cm or No Intrusion	more
V1342 — Intrusion 04 Max Intrusion Z-axis	00 cm	0 cm or No Intrusion	more
V1343 — Intrusion 04 Occupant Number	00	No contact or no intrusion	more
V1344 — Intrusion 04 Injury Number	00	No injury or no intrusion	more
V1345 — Intrusion 04 Occupant Number	00	No contact or no intrusion	more
V1346 — Intrusion 04 Injury Number	99	Contact, injury unknown or data not collected	more
V1347 — Intrusion Number 05	00	No Intrusion, None	more
V1348 — Intrusion 05 Occupant Space Number	00	No Intrusion, None	more
V1349 — Intrusion 05 Intruding Object	00	No Intrusion, None	more
V1350 — Intrusion 05 Assoc Event Number	0	No Intrusion, None	more
V1351 — Intrusion 05 Max Intrusion X-axis	00 cm	0 cm or No Intrusion	more
V1352 — Intrusion 05 Max Intrusion Y-axis	00 cm	0 cm or No Intrusion	more
V1353 — Intrusion 05 Max Intrusion Z-axis	00 cm	0 cm or No Intrusion	more
V1354 — Intrusion 05 Occupant Number	00	No contact or no intrusion	more
V1355 — Intrusion 05 Injury Number	00	No injury or no intrusion	more
V1356 — Intrusion 05 Occupant Number	00	No contact or no intrusion	more
V1357 — Intrusion 05 Injury Number	99	Contact, injury unknown or data not collected	more
V1358 — Intrusion Number 06	00	No Intrusion, None	more

V1359 — Intrusion 06 Occupant Space Number	00	No Intrusion, None	more
V1360 — Intrusion 06 Intruding Object	00	No Intrusion, None	more
V1361 — Intrusion 06 Assoc Event Number	0	No Intrusion, None	more
V1362 — Intrusion 06 Max Intrusion X-axis	00 cm	0 cm or No Intrusion	more
V1363 — Intrusion 06 Max Intrusion Y-axis	00 cm	0 cm or No Intrusion	more
V1364 — Intrusion 06 Max Intrusion Z-axis	00 cm	0 cm or No Intrusion	more
V1365 — Intrusion 06 Occupant Number	00	No contact or no intrusion	more
V1366 — Intrusion 06 Injury Number	00	No injury or no intrusion	more
V1367 — Intrusion 06 Occupant Number	00	No contact or no intrusion	more
V1368 — Intrusion 06 Injury Number	99	Contact, injury unknown or data not collected	more
V1369 — Intrusion Number 07	00	No Intrusion, None	more
V1370 — Intrusion 07 Occupant Space Number	00	No Intrusion, None	more
V1371 — Intrusion 07 Intruding Object	00	No Intrusion, None	more
V1372 — Intrusion 07 Assoc Event Number	0	No Intrusion, None	more
V1373 — Intrusion 07 Max Intrusion X-axis	00 cm	0 cm or No Intrusion	more
V1374 — Intrusion 07 Max Intrusion Y-axis	00 cm	0 cm or No Intrusion	more
V1375 — Intrusion 07 Max Intrusion Z-axis	00 cm	0 cm or No Intrusion	more
V1376 — Intrusion 07 Occupant Number	00	No contact or no intrusion	more
V1377 — Intrusion 07 Injury Number	00	No injury or no intrusion	more
V1378 — Intrusion 07 Occupant Number	00	No contact or no intrusion	more

V1379 — Intrusion 07 Injury Number	99	Contact, injury unknown or data not collected	more
V1380 — Intrusion Number 08	00	No Intrusion, None	more
V1381 — Intrusion 08 Occupant Space Number	00	No Intrusion, None	more
V1382 — Intrusion 08 Intruding Object	00	No Intrusion, None	more
V1383 — Intrusion 08 Assoc Event Number	0	No Intrusion, None	more
V1384 — Intrusion 08 Max Intrusion X-axis	00 cm	0 cm or No Intrusion	more
V1385 — Intrusion 08 Max Intrusion Y-axis	00 cm	0 cm or No Intrusion	more
V1386 — Intrusion 08 Max Intrusion Z-axis	00 cm	0 cm or No Intrusion	more
V1387 — Intrusion 08 Occupant Number	00	No contact or no intrusion	more
V1388 — Intrusion 08 Injury Number	00	No injury or no intrusion	more
V1389 — Intrusion 08 Occupant Number	00	No contact or no intrusion	more
V1390 — Intrusion 08 Injury Number	99	Contact, injury unknown or data not collected	more
V1391 — Intrusion Number 09	00	No Intrusion, None	more
V1392 — Intrusion 09 Occupant Space Number	00	No Intrusion, None	more
V1393 — Intrusion 09 Intruding Object	00	No Intrusion, None	more
V1394 — Intrusion 09 Assoc Event Number	0	No Intrusion, None	more
V1395 — Intrusion 09 Max Intrusion X-axis	00 cm	0 cm or No Intrusion	more
V1396 — Intrusion 09 Max Intrusion Y-axis	00 cm	0 cm or No Intrusion	more
V1397 — Intrusion 09 Max Intrusion Z-axis	00 cm	0 cm or No Intrusion	more
V1398 — Intrusion 09 Occupant Number	00	No contact or no intrusion	more

V1399 — Intrusion 09 Injury Number	00	No injury or no intrusion	more
V1400 — Intrusion 09 Occupant Number	00	No contact or no intrusion	more
V1401 — Intrusion 09 Injury Number	99	Contact, injury unknown or data not collected	more
V1402 — Intrusion Number 10	00	No Intrusion, None	more
V1403 — Intrusion 10 Occupant Space Number	00	No Intrusion, None	more
V1404 — Intrusion 10 Intruding Object	00	No Intrusion, None	more
V1405 — Intrusion 10 Assoc Event Number	0	No Intrusion, None	more
V1406 — Intrusion 10 Max Intrusion X-axis	00 cm	0 cm or No Intrusion	more
V1407 — Intrusion 10 Max Intrusion Y-axis	00 cm	0 cm or No Intrusion	more
V1408 — Intrusion 10 Max Intrusion Z-axis	00 cm	0 cm or No Intrusion	more
V1409 — Intrusion 10 Occupant Number	00	No contact or no intrusion	more
V1410 — Intrusion 10 Injury Number	00	No injury or no intrusion	more
V1411 — Intrusion 10 Occupant Number	00	No contact or no intrusion	more
V1412 — Intrusion 10 Injury Number	99	Contact, injury unknown or data not collected	more
V1413 — Door Intrusion Number 01	88	Not Applicable	more
V1414 — Door Intrusion Number 01 Cause	8	Not applicable	more
V1415 — Door Intrusion Number 02	88	Not Applicable	more
V1416 — Door Intrusion Number 02 Cause	8	Not applicable	more
V1417 — Door Intrusion Number 03	88	Not Applicable	more
V1418 — Door Intrusion Number 03 Cause	8	Not applicable	more
V1419 — Door Intrusion 01	88	Not Applicable	more

Component			
V1420 — Door Intrusion 01 Component Damaged 1	8	Not Applicable	more
V1421 — Door Intrusion 01 Component Damaged 2	8	Not Applicable	more
V1422 — Door Intrusion 02 Component	88	Not Applicable	more
V1423 — Door Intrusion 02 Component Damaged 1	8	Not Applicable	more
V1424 — Door Intrusion 02 Component Damaged 2	8	Not Applicable	more
V1425 — Door Intrusion 03 Component	88	Not Applicable	more
V1426 — Door Intrusion 03 Component Damaged 1	8	Not Applicable	more
V1427 — Door Intrusion 03 Component Damaged 2	8	Not Applicable	more
V1428 — Door Intrusion 04 Component	88	Not Applicable	more
V1429 — Door Intrusion 04 Component Damaged 1	8	Not Applicable	more
V1430 — Door Intrusion 04 Component Damaged 2	8	Not Applicable	more

Case Vehicle

Airbag(s)

Variable Number and Name	Code Value	Code Description	Other Options
V1501 — Driver Airbag Equipped	1	Yes	more
V1502 — Driver Airbag Deployed	1	Yes	more
V1503 — Driver Airbag Condition	0	No Damage	more
V1504 — Passenger Airbag Equip	1	Yes	more
V1505 — Passenger Airbag Deployed	1	Yes	more
V1506 — Passenger Airbag Condition	0	No Damage	more
V1507 — Steering Wheel Airbag Tether	1	Yes	more
V1508 — Driver Airbag Marked By Contact	0	No	more
V1509 — Passenger Airbag Tether	0	No	more
V1510 — Passenger Airbag Marked By Contact	0	No	more

Case Vehicle

Interior

Variable Number and Name	Code Value	Code Description	Other Options
V1601 — Left Front Door Damaged	4	Yes, occupant contact	more
V1602 — Right Front Door Damaged	0	No	more
V1603 — Left Front Hardware Damaged	4	Yes, occupant contact	more
V1604 — Right Front Hardware Damaged	0	No	more
V1605 — Left Front Armrest Damaged	4	Yes, occupant contact	more
V1606 — Right Front Armrest Damaged	0	No	more
V1607 — Left Front Glass Damaged	3	No, occupant contact	more
V1608 — Right Front Glass Damaged	0	No	more
V1609 — Left Rear Door Area Damaged	0	No	more
V1610 — Right Rear Door Area Damaged	0	No	more
V1611 — Left Rear Hardware Damaged	0	No	more
V1612 — Right Rear Hardware Damaged	0	No	more
V1613 — Left Rear Armrest Damaged	0	No	more
V1614 — Right Rear Armrest Damaged	0	No	more
V1615 — Left Rear Glass Damaged	0	No	more
V1616 — Right Rear Glass Damaged	0	No	more
V1617 — Left Roof Side Rail Damaged	0	No	more
V1618 — Right Roof Side Rail Damaged	0	No	more
V1619 — Left B-pillar Damaged	0	No	more
V1620 — Right B-pillar Damaged	0	No	more

V1621 — Left C-pillar Damaged	0	No	more
V1622 — Right C-pillar Damaged	0	No	more
V1623 — Left D-pillar Damaged	8	Not applicable	more
V1624 — Right D-pillar Damaged	8	Not applicable	more
V1625 — Left Headlining Damaged	0	No	more
V1626 — Right Headlining Damaged	0	No	more
V1627 — Left Roof Structure Damaged	0	No	more
V1628 — Right Roof Structure Damaged	0	No	more
V1629 — Left T/Sun Roof Damaged	0	No	more
V1630 — Right T/Sun Roof Damaged	0	No	more
V1631 — Other Left Side Item Damagd	8	Not applicable	more
V1632 — Other Right Side Item Damagd	8	Not applicable	more
V1633 — Foot Controls Damaged	0	No	more
V1634 — Ignition Key Damaged	0	No	more
V1635 — Rear View Mirror Damaged	0	No	more
V1636 — Sunvisor/Fitting Damaged	0	No	more
V1637 — Windshield Molding Damaged	0	No	more
V1638 — Left A-pillar Damaged	0	No	more
V1639 — Right A-pillar Damaged	0	No	more
V1640 — Center Console Damaged	0	No	more
V1641 — Transmission Lever Damaged	0	No	more
V1642 — Horn/Spoke Shroud Damagd	0	No	more
V1643 — Upper Panel Damaged	0	No	more
V1644 — Mid Panel Damaged	0	No	more
V1645 — Lower Panel Damaged	4	Yes, occupant contact	more
V1646 — Ashtray Damaged	0	No	more

V1647 — Control Knob/Lever Damaged	0	No	more
V1648 — Glove Compartment Area Damaged	0	No	more
V1649 — Instruments Damaged	0	No	more
V1650 — Park Brake Release Damaged	0	No	more
V1651 — Park Brake Pedal Damaged	0	No	more
V1652 — A/C Or Upper Vent Damaged	0	No	more
V1653 — Heater Or A/C Duct Damaged	0	No	more
V1654 — Radio Damaged	0	No	more
V1655 — Other Item Damaged	8	Not applicable	more
V1656 — Rear Window Damaged	0	No	more
V1657 — Rear Window Header Damaged	0	No	more
V1658 — Vertical Console Damaged	8	Not applicable	more
V1659 — Roof Console Damaged	0	No	more

Case Vehicle Seats

Variable Number and Name	Code Value	Code Description	Other Options
V1701 — Driver Front Seat Type	05	Bucket	more

V1702 — Passenger Front Seat Type	05	Bucket	more
V1703 — Driver Seat Mount Type	1	Standard	more
V1704 — Passenger Seat Mount Type	1	Standard	more
V1705 — Driver Swivel Mechanism Equipped	0	No	more
V1706 — Passenger Swivel Mechanism Equipped	0	No	more
V1707 — Driver Seat Original Equipment	1	Yes	more
V1708 — Passenger Seat Original Equipment	1	Yes	more
V1709 — Driver Seat/Rear Occupant Contact	8	Not applicable	more
V1710 — Passenger Seat/Rear Occupant Contact	8	Not applicable	more
V1711 — Driver Seat Damage	0	None	more
V1712 — Passenger Seat Damage	0	None	more
V1713 — Center Front Armrest Damaged	0	No	more
V1714 — Driver Seat Rotation	0	None apparent	more
V1715 — Passenger Seat Rotation	0	None apparent	more
V1716 — Driver Seat-back Type	1	Forward folding	more
V1717 — Passenger Seat-back Type	1	Forward folding	more
V1718 — Driver Seat-back Lock Type	1	Manual	more
V1719 — Passenger Seat-back Lock Type	1	Manual	more
V1720 — Driver Seat-back Lock Held	1	Yes	more
V1721 — Passenger Seat-back Lock Held	1	Yes	more
V1722 — Driver Recliner Mechanism Held	1	Yes	more
V1723 — Passenger Recliner Mechanism Held	1	Yes	more
V1724 — Driver Head Restraint Type	1	Adjustable	more
V1725 — Passenger Head Restraint	1	Adjustable	more

Type			
V1726 — Driver Head Rest Removed	0	No	more
V1727 — Passenger Head Rest Removed	0	No	more
V1728 — Driver Head Rest Adjustment	2	Down	more
V1729 — Passenger Head Rest Adjustment	2	Down	more
V1730 — Driver Head Rest Damage	0	None	more
V1731 — Passenger Head Rest Damage	0	None	more
V1732 — Driver Seat Adjustment Type	2	Power	more
V1733 — Passenger Seat Adjustment Type	1	Manual	more
V1734 — Driver Seat Adjustment Provided	3	6-way	more
V1735 — Passenger Seat Adjustment Provided	1	2-way	more
V1736 — Driver Seat Adjuster Damage	0	None	more
V1737 — Passenger Seat Adjuster Damage	0	None	more
V1738 — Driver Seat Adjuster Separation	8	Not applicable	more
V1739 — Passenger Seat Adjuster Separation	8	Not applicable	more
V1740 — Driver Seat Pre-crash Position	3	Rearward	more
V1741 — Passenger Seat Pre-crash Position	2	Middle	more
V1742 — Left Rear Seat Type	2	Folding	more
V1743 — Right Rear Seat Type	2	Folding	more
V1744 — Left Rear Seat Damaged	0	None	more
V1745 — Right Rear Seat Damaged	0	None	more
V1746 — Center Rear Armrest Damaged	8	Not applicable (No Center Armrest)	more

V1747 — Left Rear Seat-back Left Lock Equipped	1	Yes	more
V1748 — Right Rear Seat-back Left Lock Equipped	0	No	more
V1749 — Left Rear Seat-back Left Lock Held	1	Yes	more
V1750 — Right Rear Seat-back Left Lock Held	8	Not applicable	more
V1751 — Left Rear Seat-back Right Lock Equipped	0	No	more
V1752 — Right Rear Seat-back Right Lock Equipped	1	Yes	more
V1753 — Left Rear Seat-back Right Lock Held	8	Not applicable	more
V1754 — Right Rear Seat-back Right Lock Held	1	Yes	more
V1755 — Left 3rd Seat Equipped	0	No	more
V1756 — Right 3rd Seat Equipped	0	No	more
V1757 — Left 3rd Seat Backrest Damaged	8	Not applicable	more
V1758 — Right 3rd Seat Backrest Damaged	8	Not applicable	more
V1759 — Left 3rd Seat Cushion Damaged	8	Not applicable	more
V1760 — Right 3rd Seat Cushion Damaged	8	Not applicable	more
V1761 — Rear Head Restraints	1	Equipped	more

MEASUREMENTS IN CENTIMETERS

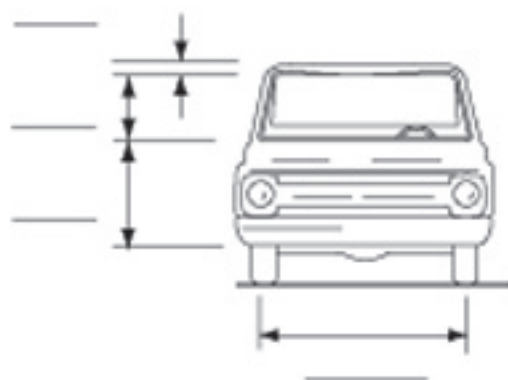

This vehicle was unavailable for inspection.

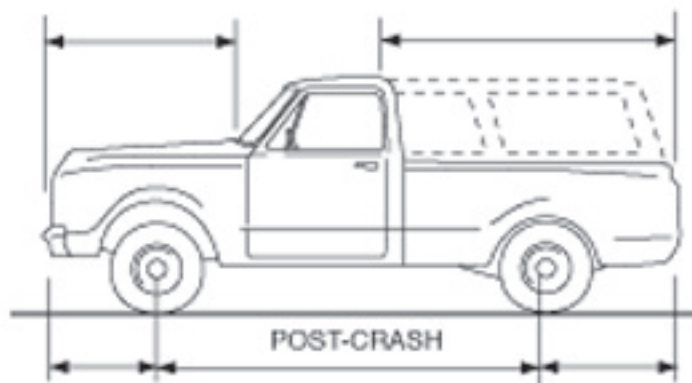
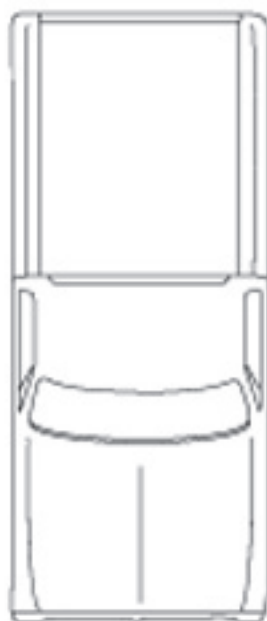
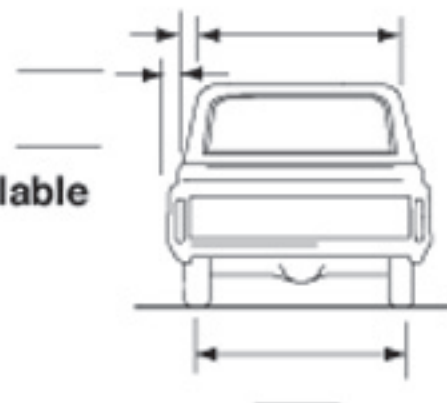

Bumper corner _____ Bumper corner _____
Stringline _____ Stringline _____

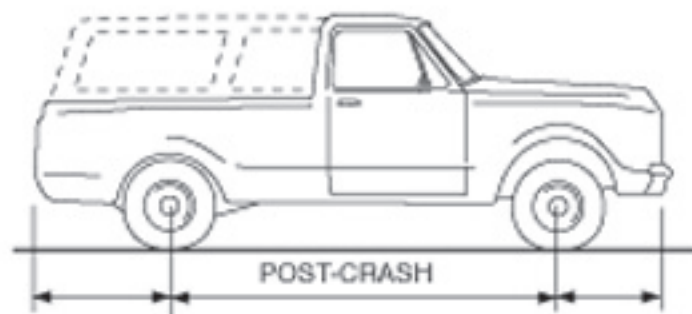

Bumper corner _____ Bumper corner _____
Stringline _____ Stringline _____

WINDSHIELD MARK ON CASE VEHICLE:

SOLAR TINT



(N)

(R)

LAMINATED
SUN VISOR AS1
DOT-75 FM-M180

1 A

F

DW-1206

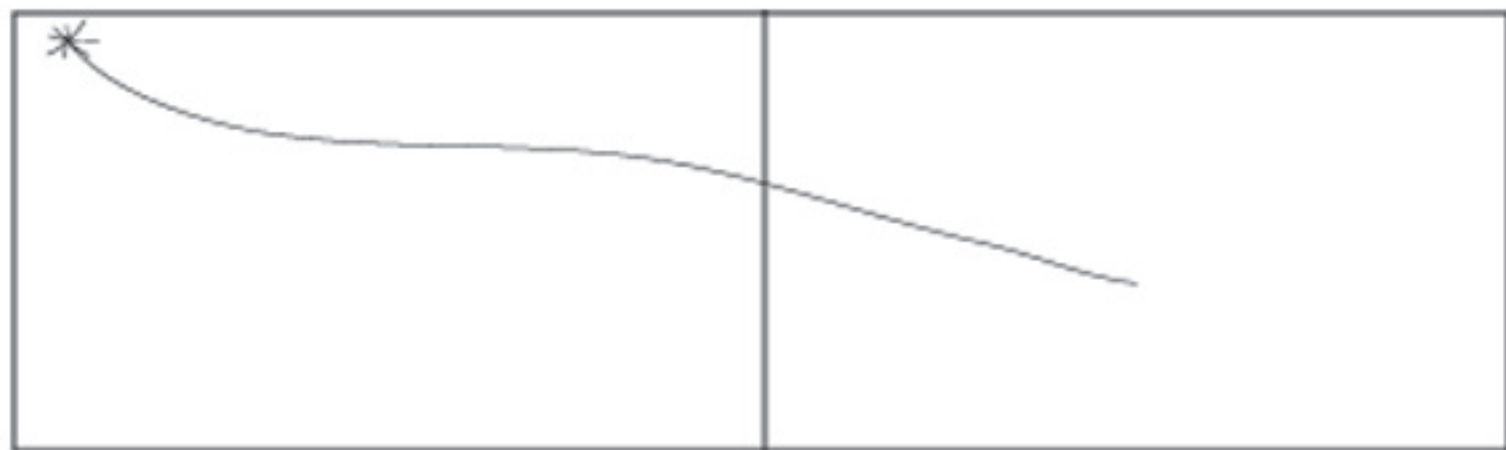

Windshield cracked on left due to contact by an exterior object

1 = Definitely 2 = Probably 3 = Possible

INTRUSION IT-1

Location of Intrusion	Intruded Component	(All Measurements Are in Centimeters)			Dominant Crush Direction
		Comparison Value	–	Intruded Value = Intrusion	
	None		–	=	
			–	=	
			–	=	
			–	=	
			–	=	
			–	=	
			–	=	
			–	=	

OCCUPANT CONTACT WORKSHEET

Contact	Interior Component Contacted	Occupant No. if Known	Body Region if Known	Supporting Physical Evidence	Confidence Level of Contact Point
A	Driver door window	Dr	Head	blood deposit	2
B	Driver door panel, hardware and armrest	DR	Lt. leg	cloth patterned scuffmark	1
C	Upper airbag flap & steering-wheel hub	DR	UX	scuffmark	1
D	Knee bolster	DR	Rt. Leg	scuffmark	1
E					

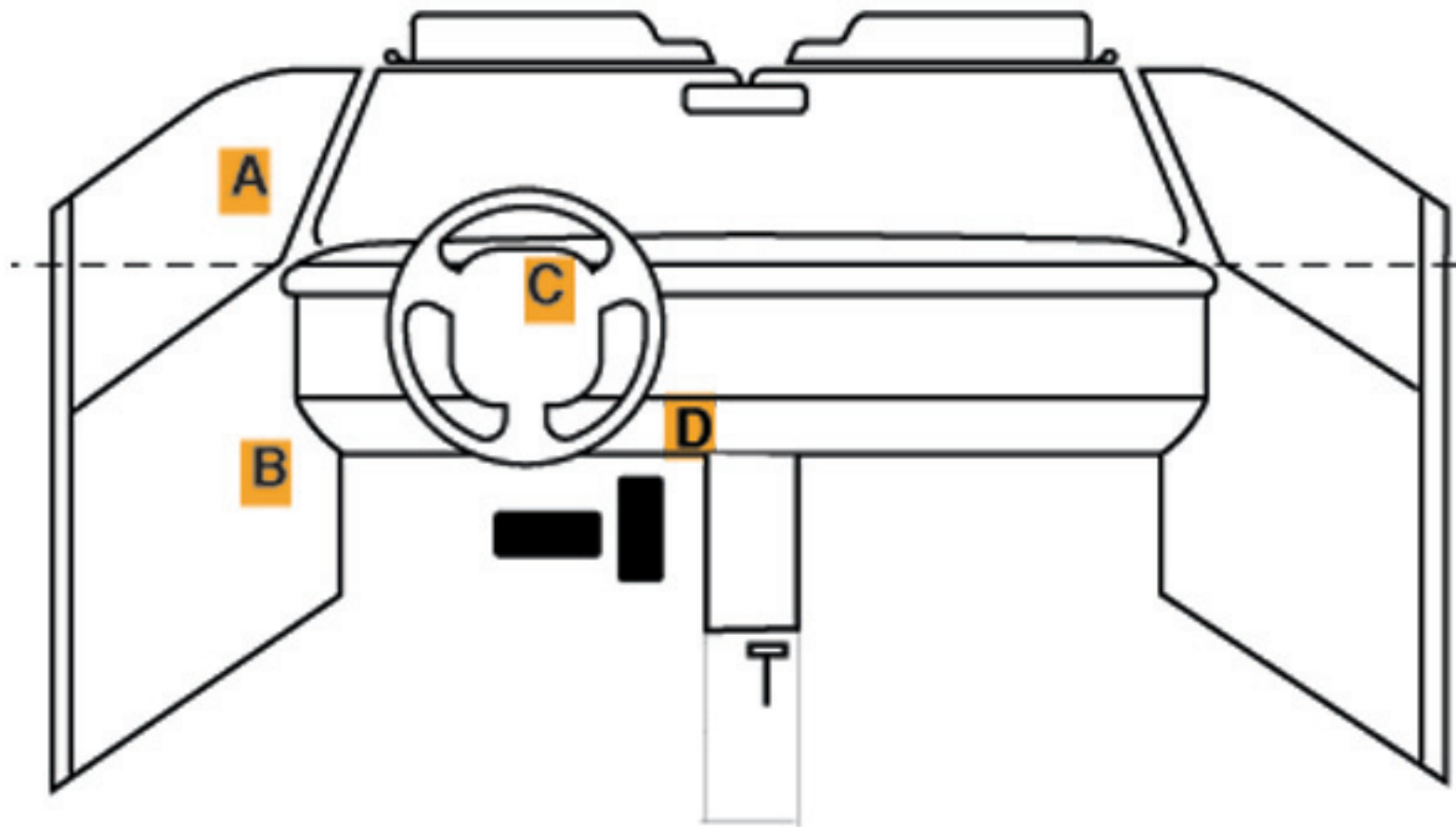

A = driver door window, blood deposit

B = driver door panel, hardware and armrest, cloth patterned scuffmark

C = upper airbag flap and steering-wheel hub, scuffmark

D= knee bolster, scuffmark

Driver Airbag

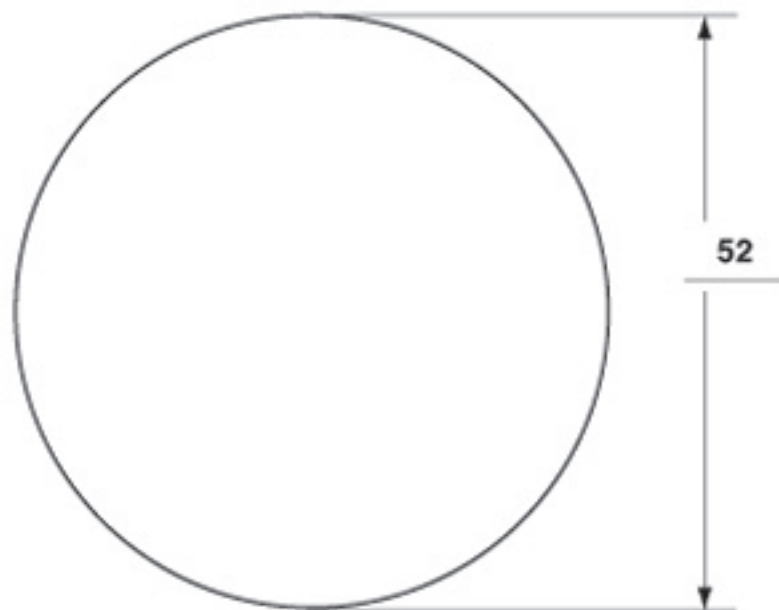

Driver Airbag Doors

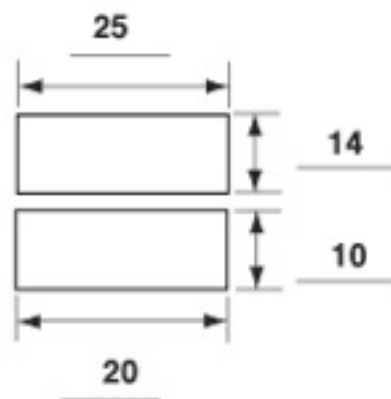

Vents: Y N
if yes, how many: 2

at 1 and 11 o'clock

Tethers: Y N
if yes, how many: 2

Passenger Airbag

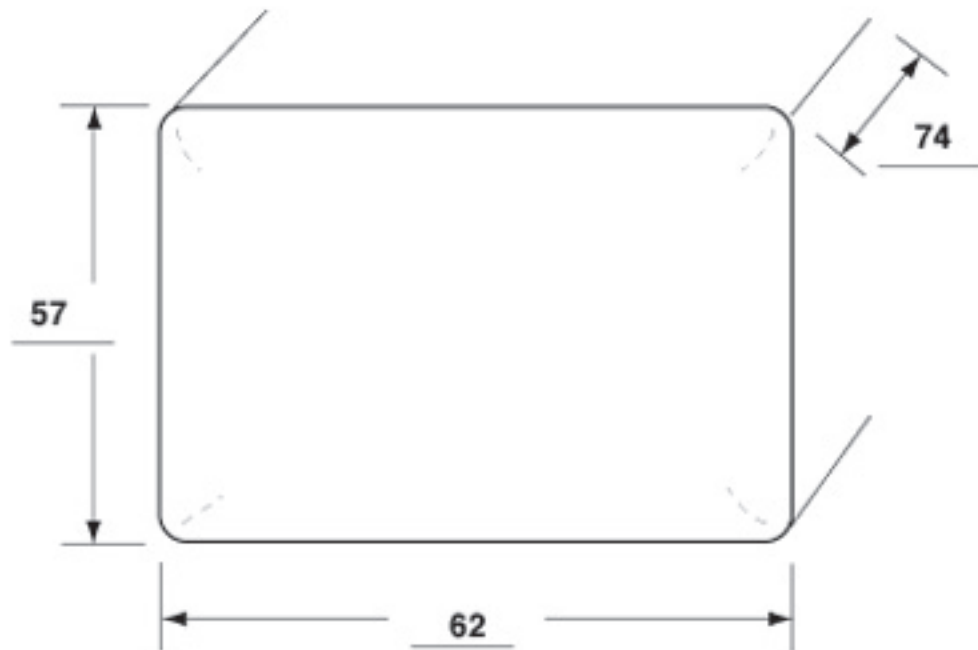

Passenger Airbag Door

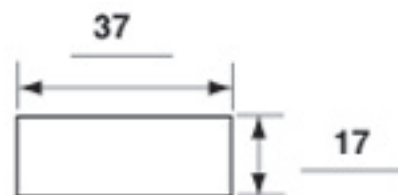

Vents: Y N
if yes, how many: 2
3 and 9 o'clock on sides

Tethers: Y N
if yes, how many: _____

Case # 371: Occupant # 1; Injury # 1

Variable Number and Name	Code Value	Code Description	Other Options
V2101 — Injury Number	01	Injury #1	more
V2102 — 1st Prob Contact Area	87	Air cushion skin "airbag"	more
V2103 — 2nd Prob Contact Area	00	No Contact/not applicable	more
V2104 — Primary OIC -body Region	06	Face	more
V2105 — Primary OIC -aspect	03	Central	more
V2106 — Primary OIC -lesion	12	Laceration	more
V2107 — Primary OIC -system/Organ	09	Integumentary	more
V2108 — Primary OIC -severity	1	Minor	more
V2109 — Primary OIC	FCL11	—	—
V2110 — Assoc OIC 1 -body Region	99	No injury	more
V2111 — Assoc OIC 1 -aspect	99	No injury	more
V2112 — Assoc OIC 1 -lesion	99	No injury	more
V2113 — Assoc OIC 1 -system/Organ	99	No injury	more
V2114 — Assoc OIC 1 -severity	9	Unknown	more
V2115 — Assoc OIC 1	—	—	—

Case # 371: Occupant # 1; Injury # 2

Variable Number and Name	Code Value	Code Description	Other Options
V2101 — Injury Number	02	Injury #2	more
V2102 — 1st Prob Contact Area	34	Restraint system webbing	more
V2103 — 2nd Prob Contact Area	00	No Contact/not applicable	more
V2104 — Primary OIC -body Region	19	Shoulder	more
V2105 — Primary OIC -aspect	12	Left	more
V2106 — Primary OIC -lesion	03	Contusion	more
V2107 — Primary OIC -system/Organ	09	Integumentary	more
V2108 — Primary OIC -severity	1	Minor	more
V2109 — Primary OIC	SLCI1	—	—
V2110 — Assoc OIC 1 -body Region	99	No injury	more
V2111 — Assoc OIC 1 -aspect	99	No injury	more
V2112 — Assoc OIC 1 -lesion	99	No injury	more
V2113 — Assoc OIC 1 -system/Organ	99	No injury	more
V2114 — Assoc OIC 1 -severity	9	Unknown	more
V2115 — Assoc OIC 1	—	—	—

Case # 371: Occupant # 1; Injury # 3

Variable Number and Name	Code Value	Code Description	Other Options
V2101 — Injury Number	03	Injury #3	more
V2102 — 1st Prob Contact Area	34	Restraint system webbing	more
V2103 — 2nd Prob Contact Area	00	No Contact/not applicable	more
V2104 — Primary OIC -body Region	13	Abdomen	more
V2105 — Primary OIC -aspect	23	Whole region	more
V2106 — Primary OIC -lesion	03	Contusion	more
V2107 — Primary OIC -system/Organ	09	Integumentary	more
V2108 — Primary OIC -severity	1	Minor	more
V2109 — Primary OIC	MWCI1	—	—
V2110 — Assoc OIC 1 -body Region	99	No injury	more
V2111 — Assoc OIC 1 -aspect	99	No injury	more
V2112 — Assoc OIC 1 -lesion	99	No injury	more
V2113 — Assoc OIC 1 -system/Organ	99	No injury	more
V2114 — Assoc OIC 1 -severity	9	Unknown	more
V2115 — Assoc OIC 1	—	—	—

Case # 371: Occupant # 1

Variable Number and Name	Code Value	Code Description	Other Options
V2001 — Occupant Number	01	Occupant #1	more
V2002 — Occupant Role At 1st Impact	1	Motor vehicle driver	more
V2003 — Occupant Position -row	1	1st row	more
V2004 — Occupant Position -lateral	1	Left	more
V2005 — Occupant Position -posture	10	Sitting on seat	more
V2006 — Occupant Age In Years	26	—	—
V2007 — Occupant Age In Months	25	25 months or older	more
V2008 — Occupant Mass	086 kg	—	—
V2009 — Occupant Height	178 cm	—	—
V2010 — Occupant Sex	1	Male	more
V2011 — Occupant Treatment/Mortality	02	Treated at hospital/clinic but not admitted	more
V2012 — Injury Severity Score	01	ISS 1	more
V2013 — Non-impact Med Condition	0	None	more
V2014 — Police Injury Severity	1	C - Possible injury	more
V2015 — Active Restraint System	3	Both lap belt and shoulder harness	more
V2016 — Active Restraint Usage	3	Both lap belt and shoulder harness	more
V2017 — Passive Restraint System	1	Air bag installed	more
V2018 — Passive Restraint Usage	2	Air bag deployed	more
V2019 — Child Seat Type	88	Not applicable (adult or older child)	more
V2020 — Occupant Ejection Degree	0	None	more
V2021 — Occupant Ejection Area	98	Not applicable (not ejected)	more

V2022 — Highest OIC Severity	1	Minor	more
V2023 — Head Restraint Available	1	Equipped	more
V2024 — Occupant Eyewear	0	None	more
V2025 — Source of Occupant Info	7	Combination of above	more

TRUCK
CROSSING













6947





6947

F150









694



6947



6947

F

Platinum





WARNING
BATTERY ACID IS EXTREMELY DANGEROUS. IT CAN CAUSE SEVERE BURNS AND DAMAGE TO YOUR EYES AND SKIN. ALWAYS WEAR PROTECTIVE GEAR AND NEVER DRINK OR SMOKE WHILE WORKING ON THE BATTERY.

DANGER/POISON
BATTERY ACID IS EXTREMELY DANGEROUS. IT CAN CAUSE SEVERE BURNS AND DAMAGE TO YOUR EYES AND SKIN. ALWAYS WEAR PROTECTIVE GEAR AND NEVER DRINK OR SMOKE WHILE WORKING ON THE BATTERY.

CAUTION
DO NOT ATTEMPT TO REPAIR OR MAINTAIN THIS EQUIPMENT UNLESS YOU ARE A QUALIFIED TECHNICIAN. ALWAYS USE THE CORRECT TOOLS AND FOLLOW THE MANUFACTURER'S INSTRUCTIONS.







6947

CONTINUED



6947





































MRAB in Film
qhering

CVT









WARNING

COLLISION WRAP...
Self-Adjusting...
See...



SRS
AIRBAG





WARNING

WARNING



WARNING

WARNING

ION / MOI

ION / MOI















COLLISION WRAP - Film
Self-Adhering
GTX

COLLISION WRAP - Film
Self-Adhering
GTX

COLLISION WRAP - Film
Self-Adhering
GTX

VISION WRAP™ Film
Self-Adhering





